



XF SERIES

DIESEL / GASOLINE / LPG
COUNTERBALANCED TRUCKS

with capacities of 1,000 to 3,500kg

HANGCHA GROUP CO., LTD.

Factory site: 666 Xiangfu Road,
Hangzhou, Zhejiang, China (311305)

Tel: +86-571-88926735 88926755
Fax: +86-571-88926789 88132890

sales@hcforklift.com www.hcforklift.com



Follow us on
Facebook



Follow us on
YouTube



Follow us on
WeChat



Download "Hangcha
Forklift" App



ISO45001:2018



ISO14001:2015



ISO9001:2015



HANGCHA trucks conform
to the European Safety
Requirements.

HANGCHA GROUP CO., LTD. reserves the right to make any changes without notice concerning colors, equipment, or specifications detailed in this brochure, or to discontinue individual models. The colors of trucks, delivered may differ slightly from those in brochures.

HANGCHA be with you at every stage

Efficient, reliable solutions for your demands



STAGE V & TIER 4F

With Hangcha you can meet all Stage V/Tier 4f emissions standards which provides customer demands for value, innovation and performance. The technologies include common rail fuel systems, diesel oxidation catalysts (DOC) and diesel particulate filters (DPF). Designed and optimised to every engine model, our forklift truck maximises efficiency and reliability.



KUBOTA

► Emissions Compliance

Meeting rigid emissions regulations can be a challenge for any company. V2607-CR-E5B engines have been designed to comply with stringent regulations: EU StageV EPA/CARB Tier4 F.

► Advanced DPF Technology

► Clean and Quiet Power

► Great Flexibility



XINCHAI

No.	Capacity	Series	Manufacturer	Engine	Drive power	Model	Emission Std.	Transmission	Power (kw/rpm)
1	1.5-3.5t	XF	KUBOTA	V2607-CR-E5B	Diesel	CPCD15/18/20/25/30/35-XW97F/B1	EU StageV EPA/CARB Tier4 F	F/OKAMURA	37.4/2400
2	2.0-3.5t	XF	KUBOTA	V2607-CR-TE5B	Diesel	CPCD20/25/30/35-XW98F	EU StageV EPA/CARB Tier4 F	F	47.3/2400
3	1.5-1.75t	XF	XINCHAI	3E22YG51P464	Diesel	CPCD15/18/-XH7F/B1	Stage V	F/OKAMURA	34/2400
4	2.0-3.5t	XF	XINCHAI	3E22YG51	Diesel	CPCD20/25/30/35-XH7F/B1	Stage V	F/OKAMURA	44.8/2400

Note: Stage V applied for European Union also including Israel and Turkey
Tier4 Final applied for North American
F means full floating transmission

GCT



► Eco-friendly engines compliant with global emission regulations. Global standard forklift engines with top-class of output and reliability performance.

ENGINE TYPE	Vertical Inline 4-cylinder · Water cooled · OHV
FUEL	Gasoline · LPG
FUEL SYSTEM	Electronic Controlled, Gasoline : Injector · LPG : Injector
EMISSION REGULATION	CARB SIP LSI-1/ EPA Tier2/ EU STAGE V

No.	Capacity	Series	Manufacturer	Engine	Drive power	Model	Emission Std.	Transmission	Power (kw/rpm)
1	1.5-1.75t	XF	GCT	GCT GK21LPG EU-StageV CERT	LPG	CPYD15/18-XH1F/B	Stage V	F/OKAMURA	38.4/2700
2	2.0-3.5t	XF	GCT	GCT GK25LPG EU-StageV CERT	LPG	CPYD20/25/30/35-XH3F/B	Stage V	F/OKAMURA	43.4/2700
3	1.5-1.75t	XF	GCT	GCT GK21 LPG 1G001 EKHO0	LPG	CPYD15/18-XH23F/B1	CARB SIP LSI-1/ EPA Tier2/ EU STAGE V	F/OKAMURA	43/2700
4	1.5-1.75t	XF	GCT	GCT GK21 DUAL 1G001 ECH00	DUAL LPG/GAS	CPQYD15/18-XH24F/B1		F/OKAMURA	LP-43/2700 G-40/2700
5	2.0-3.5t	XF	GCT	GCT GK25 LPG 1G001 ELHO0	LPG	CPYD20/25/30/35-XH21F/B1		F/OKAMURA	47/2700
6	2.0-3.5t	XF	GCT	GCT GK25 DUAL 1G001 EDHO0	DUAL LPG/GAS	CPQYD20/25/30/35-XH22F/B1		F/OKAMURA	LP-47/2700 G-44.5/2700

Note: Stage V applied for European Union also including Israel and Turkey
Tier4 Final applied for North American
F means full floating transmission

COMFORTABLE OPERATION

Optimal visibility in all directions create the best conditions for high productivity through relaxed and safe working.



▶ The new, relocated easy-to-see LCD meter lets the operator check on all aspects of operational status at a glance.



▶ The new automobile-style light/turn-signal lever and forward-reverse lever are ergonomically designed and arranged to improve comfort and productivity.

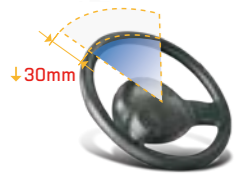

▶ The small diameter steering wheel with tilt adjustment provides the ideal operating position. The superior responsiveness of the steering wheel optimizes maneuverability even in narrow spaces.



▶ The parking brake is specially developed. The operational force is reduced by 30%.



▶ The automobile-style suspended pedals provide more ergonomic operation.



In developing the new XF Series, comfort and ease of operation is carefully considered, for example, to improve vibration levels, compound engine damper and full floating power train are adopted. Comfortable operating environments for operator also contribute to increased productivity.



In addition to rubber damper between frames and steering axle, compound engine damper and full floating power train achieve flexible connection between frames and driving system, as a result, traveling vibrations and vibrations from the driving system are significantly reduced.

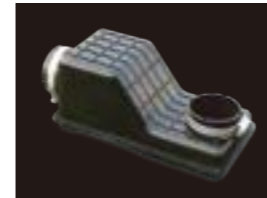

The enlarged capacity of optimized exhaust muffler, the intake muffler and the noise shield technologies provide significantly lower noise levels.

▶ The optional Electro-hydraulic proportional control system contributes more sensitive and precise load handling. The easy-to-operate levers provide total load handling operation. An armrest is provided to reduce fatigue.



The new wide-open, non-slip step makes getting in and out easy and safe.

EASY MAINTENANCE

Careful design facilitates inspection and servicing. Easy maintenance reduces the amount of downtime and helps to reduce cost also.

▶ The cover on the Panel can be lifted up simply to check the brake fluid.

▶ The easy-to-operate latch provides quick access to the engine compartment.

▶ The two-piece design makes the floorboard easy to lift and remove for access to the power train.

▶ The fasteners of the radiator cover can be turned easily by hand to enable quick inspections or servicing.



SOFTLY

▶ In addition to the soft landing system, the soft lifting system is adopted (front lifting cylinders of triplex mast and full free duplex mast), as a result, the noise and shock of the mast significantly decreases.

WIDER

▶ The developed front lifting cylinders with smaller outer diameter give the operator superior forward visibility. The double lifting cylinders provide better forward visibility.

WIDER

WIDER 90%

▶ The extra foot space is provided to reduce operator fatigue significantly.

PRODUCTIVITY

Dynamic load sensing hydraulic steering system, Efficiency lighting system, lower fuel consumption, combine to provide increased productivity and reduced operating costs.



Interactive instrument: The instrument adopts 4.0-inch color LCD display with four interactive buttons, and has one CAN bus communication function. The communication protocol is compatible with CANopen and SAE J1939 standards.

The new Dynamic load sensing hydraulic steering system contributes to reduce loss of hydraulic and improve energy efficiency.

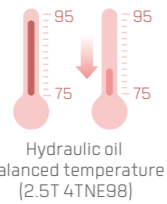

By optimizing transmission design, the power train provides higher efficiency. The fuel consumption is reduced **by 10%.**

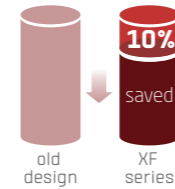

The new efficiency lighting system employs LED illuminant and new type reflector to reduce energy consumption, improve significantly illumination performance and prolong work time.

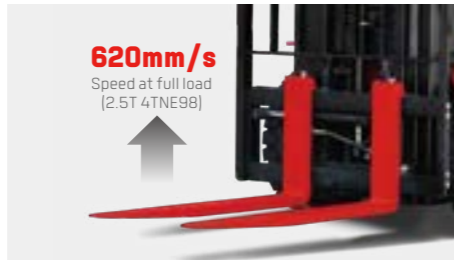

SAFETY

A wide range of technologies are applied to ensure absolute safety for both the operator and those in the surrounding.

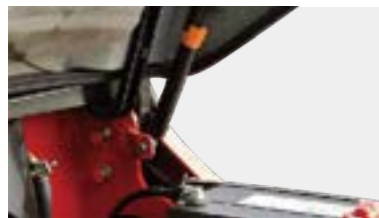

▶ The locking device of the engine hood damper and parking brake help add to safety.



▶ An optional rear-pillar assist grip with a horn button enhances safety of operator while traveling in reverse.



▶ The operator presence sensing system incorporates lifting/tilting and traveling locking function. When the operator leaves the seat, the system automatically locks lifting / tilting and disables traveling to ensure safety.

▶ A throttling device is adopted to avoid the mast being out of control even some pipes are broken.

RELIABILITY

By focusing on enhancing reliability, reducing downtime, the XF series is able to make the greater productivity for customer.



▶ The new aluminum alloy transmission with full floating structure features excellent heat dissipation capability, more and thicker disc meet the most demanding applications.



▶ The new stamped air cleaner featuring tangential intake, double seal with safety filter is durable, corrosion-free and vibration-resistant, provides better filter efficiency and lower intake resistance than the previous.



▶ The new vehicle controller integrates all electrical components, features excellent durability for temperature, water and vibration for most demanding operation.

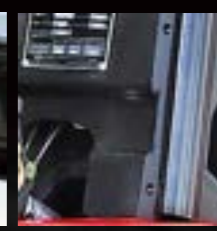

▶ Extra capacity combined radiator with serpentine wave and optimized heat dissipation channel enhance the heat dissipation capability to keep engine reliability even in heavy-duty applications.

▶ XF series features rugged design, stamped frame and engine hood, stamped instrument panel and head guard, heavy profile rail mast combine to provide excellent rigidity, which ensures outstanding reliability even in heavy-duty work.



Features

Truck	Standard	Options
PVC ceiling	●	
Multifunctional interactive instruments(EU StageV)	●	
Wide-view rearview mirror	●	
Tilt Cylinder Boot	●	
Combination LED lighting system	●	
Steering wheel adjusting device	●	
Traction pin	●	
Counterweight grille cover	●	
Dual front wheel		○
Perforated overhead guard		○
Cab		○
Additional L/R rearview mirrors		○
Heater		○
Fire extinguisher (1kg)		○
Front windshield and wiper		○
Fully-suspended seat		○
Customer paint		○
External spark extinguisher		○
LED rear working light		○
Solid tire		○
Rotating handle of water tank lid		○
Fan		○
Fuel tank cap with lock		○
Right rear armrest with horn button		○
Reinforced wheel rim		○
Steering		
Wet braking drive axle		○
Chassiss		
Skidproof pedal	●	
Rubber pedal	●	
Engine hood spring	●	
Control		
Mechanical handbrake	●	
Integrated combination switch	●	
Fingertip system		○
Multi-segment adjustable speed limit		○
Hydraulic		
Electro-hydraulic steering	●	
Hydraulic oil recycling filter	●	
Speed limiting valve of the mast	●	
2nd valve	●	
Combination LED lighting system		○
5th valve		○
Power		
High-efficiency air intake silencer	●	
Fan protection device	●	
Dissipater grille cover		○
Dual air filter		○
High-position exhauster		○
Electronics		
Low-temperature starting battery	●	
OPS system	●	
Blue light	●	
Audible and visual alarm	●	○

Mast	Standard	Options
Duplex mast	●	
Full free duplex mast		○
Triplex mast		○
Wider fork carriage		○
Heightened load backrest		○
Different length of fork		○
Transmission		
Fully-suspended gearbox	●	
High-efficiency air filter	●	
Low-noise gear pump		○
Attachments		
Paper roll clamp		○
Sideshifter		○
Soft package clamp		○
Carton clamp		○
Rotatable roll clamp		○
Rotating fork		○
Oil barrel clamp		○
Push-pull device		○
Load stabilizer		○
Fork sleeve		○
Tipping clamp		○
Bucket		○
Multi-purpose barrel clamp		○
Crane arm		○
Hook		○
String Pole		○
Weighing system		○
Special fork		○

Technical data

		HANGCHA GROUP CO.,LTD.																														
Distinguishing mark	1.1	Manufacturer																														
	1.2	Manufacturer's type designation	CPCD10-XW32F/B	CPYD15-XH1F/B	CPCD15-XH7F/B1	CPCD15-XW97F/B1	CPYD18-XH1F/B	CPCD18-XH7F/B1	CPCD18-XW97F/B1	CPYD20-XH3F/B	CPCD20-XH7F/B1	CPYD25-XH3F/B	CPCD25-XH7F/B1	CPYD30-XH3F/B	CPCD30-XH7F/B1	CPYD35-XH3F/B	CPCD35-XH7F/B1															
	1.3	Drive: electric (battery or mains), diesel, petrol, fuel gas	Diesel	LPG	Diesel	Diesel	LPG	Diesel	Diesel	LPG	Diesel	LPG	Diesel	LPG	Diesel	LPG	Diesel															
Weight	1.5	Rated capacity/rated load	Q (kg)	1000	1500	1500	1500	1750	1750	1750	2000	2000	2500	2500	3000	3000	3500	3500														
	1.6	Load centre distance	c(mm)	500	500	500	500	500	500	500	500	500	500	500	500	500	500	500														
	1.8	Load distance, centre of drive axle to fork	x(mm)	405	405	405	405	405	405	405	465	465	465	465	480	480	485	485														
		Rear overhang	mm	375	405	405	405	430	430	430	415	415	490	490	550	550	615	615														
	1.9	Wheelbase	y(mm)	1475	1475	1475	1475	1475	1475	1650	1650	1650	1650	1700	1700	1700	1700	1700														
	2.1	Service Weight	kg	2510	2650	2650	2650	2765	2765	2765	3405	3405	3765	3765	4350	4350	4705	4705														
	2.2	Axle loading, laden front/rear	kg	3055/455	3660/490	3660/490	3660/490	3995/520	3995/520	3995/520	4705/700	4705/700	5475/790	5475/790	6450/900	6450/900	7255/950	7255/950														
	2.3	Axle loading, unladen front/rear	kg	1260/1250	1240/1410	1240/1410	1240/1410	1225/1540	1225/1540	1225/1540	1610/1795	1610/1795	1560/2205	1560/2205	1750/2600	1750/2600	1720/2985	1720/2985														
	3.2	Tyre size, front		6.50-10-10PR	6.50-10-10PR	6.50-10-10PR	6.50-10-10PR	6.50-10-10PR	6.50-10-10PR	6.50-10-10PR	7.00-12-12PR	7.00-12-12PR	7.00-12-12PR	7.00-12-12PR	28x9-15-14PR	28x9-15-14PR	28x9-15-14PR	28x9-15-14PR														
	3.3	Tyre size, rear		5.00-8-10PR	5.00-8-10PR	5.00-8-10PR	5.00-8-10PR	5.00-8-10PR	5.00-8-10PR	5.00-8-10PR	6.00-9-10PR	6.00-9-10PR	6.00-9-10PR	6.00-9-10PR	6.50-10-10PR	6.50-10-10PR	6.50-10-10PR	6.50-10-10PR														
Tyres, chassis	3.6	Tread, front	b10 (mm)	900	900	900	900	900	900	965	965	965	965	1005	1005	1005	1005															
	3.7	Tread, rear	b11 (mm)	920	920	920	920	920	920	973	973	973	973	975	975	975	975															
	4.1	Tilt of mast/fork carriage forward/backward	α/β(°)	6/12	6/12	6/12	6/12	6/12	6/12	6/12	6/12	6/12	6/12	6/12	6/12	6/12	6/12															
	4.2	Height, mast lowered	h1 (mm)	1995	1995	1995	1995	1995	1995	2035	2035	2035	2035	2050	2050	2165	2165															
	4.3	Free lift	h2 (mm)	155	155	155	155	155	155	140	140	140	140	145	145	145	145															
	4.4	Lift	h3 (mm)	3000	3000	3000	3000	3000	3000	3000	3000	3000	3000	3000	3000	3000	3000	3000														
	4.5	Height, mast extended	h4 (mm)	3955	3955	3955	3955	3955	3955	4045	4045	4045	4045	4145	4145	4145	4145															
	4.7	Height of overhead guard (cabin)	h6 (mm)	2125(2205*)	2125(2205*)	2125(2205*)	2125(2205*)	2125(2205*)	2125(2205*)	2135(2215*)	2135(2215*)	2135(2215*)	2135(2215*)	2135(2215*)	2150(2230*)	2150(2230*)	2150(2230*)	2150(2230*)														
	4.20	Length to face of forks	l2 (mm)	2255	2285	2285	2285	2310	2310	2310	2530	2530	2605	2605	2730	2730	2800	2800														
	Dimensions	4.21	Overall width	b1 (mm)	1080	1080	1080	1080	1080	1080	1155	1155	1155	1155	1225	1225	1225	1225														
4.22		Fork dimensions	s/e/l (mm)	920x100x35	920x100x35	920x100x35	920x100x35	920x100x35	920x100x35	920x100x35	1070x122x40	1070x122x40	1070x122x40	1070x122x40	1070x122x45	1070x122x45	1070x122x50	1070x122x50														
4.24		Fork-carriage width	b3 (mm)	1000	1000	1000	1000	1000	1000	1038	1038	1038	1038	1100	1100	1100	1100															
4.25		Distance between fork-arms	mm	200-1000	200-1000	200-1000	200-1000	200-1000	200-1000	244-1038	244-1038	244-1038	244-1038	244-1100	244-1100	244-1100	244-1100															
4.31		Ground clearance, laden, below mast	m1 (mm)	115	115	115	115	115	115	115	115	115	115	130	130	130	130															
4.32		Ground clearance, centre of wheelbase	m2 (mm)	140	140	140	140	140	140	140	150	150	150	150	165	165	165	165														
4.35		Turning radius	Wa (mm)	1965	1990	1990	1990	2015	2015	2015	2180	2180	2245	2245	2340	2340	2415	2415														
		Min. right angle stacking aisle width (Add load length and clearance)	mm	2370	2395	2395	2395	2420	2420	2420	2645	2645	2710	2710	2835	2835	2900	2900														
Performance data		5.1	Travel speed, laden/unladen	km/h	18/19	17/18	19/20	18/19	17/18	19/20	18/19	18/19	18/19	18/19	17/18	18/19	17/18	18/19														
		5.2	Lift speed, laden/unladen	m/s	0.58/0.60	0.53/0.55	0.58/0.60	0.58/0.60	0.53/0.55	0.58/0.60	0.58/0.60	0.58/0.60	0.58/0.58	0.60/0.62	0.56/0.58	0.60/0.62	0.51/0.54	0.48/0.51	0.46/0.49	0.42/0.45												
	5.3	Lowering speed, laden/unladen	m/s	0.45/0.50	0.45/0.50	0.45/0.50	0.45/0.50	0.45/0.50	0.45/0.50	0.45/0.50	0.45/0.50	0.45/0.50	0.45/0.50	0.45/0.50	0.45/0.50	0.45/0.50	0.45/0.50	0.45/0.50														
	5.5	Drawbar pull, laden/unladen	N	14600/10000	14600/10000	14500/10000	16800/10000	14600/10000	14500/10000	16800/10000	14500/10000	18700/12500	19500/12500	18700/12500	19500/14000	19800/14000	20500/14000	19800/14000	20500/14000													
	5.7	Gradeability, laden/unladen*	%	31/25	27/25	27/25	30/25	24/25	24/25	28/25	26/25	27/25	23/25	24/25	21/22	23/22	20/22	21/22														
Combustion-engine	7.1	Engine manufacturer / type	YANMAR/4TNE92		GCT GK21 LPG EU StageV		3E22YG51P464		KUBOTA V2607-CR-E5B		GCT GK21 LPG EU StageV		3E22YG51P464		KUBOTA V2607-CR-E5B		GCT GK25 LPG EU StageV		XINCHAI 3E22YG51		GCT GK25 LPG EU StageV		XINCHAI 3E22YG51		GCT GK25 LPG EU StageV		XINCHAI 3E22YG51		GCT GK25 LPG EU StageV		XINCHAI 3E22YG51	
		Emission STD	EU StageIIA/EPA Tier3		EU StageV		EU StageV		EU StageV/ EPA Tier4 F		EU StageV		EU StageV		EU StageV/EPA Tier4 F		EU StageV		EU StageV		EU StageV		EU StageV		EU StageV		EU StageV		EU StageV			
	7.2	Engine power according to DIN ISO 1585	kw	32.8	38.4	34	37	38.4	34	37	38.4	34	43.4	44.8	43.4	44.8	43.4	44.8	43.4	44.8	43.4	44.8	43.4	44.8	43.4	44.8	43.4	44.8	43.4	44.8		
	7.3	Rated speed	min	2450	2700	2400	2400	2700	2400	2400	2700	2400	2700	2400	2700	2400	2700	2400	2700	2400	2700	2400	2700	2400	2700	2400	2700	2400	2700			
	7.4	Number of cylinders/displacement	[-]/[cm³]	4/2659	4/2065	3/2227	4/2615	4/2065	3/2227	4/2615	4/2065	3/2227	4/2488	3/2227	4/2488	3/2227	4/2488	3/2227	4/2488	3/2227	4/2488	3/2227	4/2488	3/2227	4/2488	3/2227	4/2488	3/2227	4/2488			
	7.10	Battery voltage/nominal capacity	V/Ah	12/60	12/60	12/90	12/90	12/60	12/90	12/60	12/90	12/60	12/90	12/60	12/90	12/60	12/90	12/60	12/90	12/60	12/90	12/60	12/90	12/60	12/90	12/60	12/90	12/60	12/90			
		Rated torque	N·m/r/min	142/1600	151/1600	150/1600-1800	171.5/1500	151/1600	150/1600-1800	171.5/1500	188/1600	210/1600-1800	188/1600	210/1600-1800	188/1600	210/1600-1800	188/1600	210/1600-1800	188/1600	210/1600-1800	188/1600	210/1600-1800	188/1600	210/1600-1800	188/1600	210/1600-1800						
		Bore - stroke	mm	92x100	89x83	94x107	87x110	89x83	94x107	87x110	89x100	94x107	89x100	94x107	89x100	94x107	89x100	94x107	89x100	94x107	89x100	94x107	89x100	94x107	89x100	94x107						
		Transmissions Manufacturer	HANGCHA/OKAMURA		HANGCHA/OKAMURA		HANGCHA/OKAMURA		HANGCHA/OKAMURA		HANGCHA/OKAMURA		HANGCHA/OKAMURA		HANGCHA/OKAMURA		HANGCHA/OKAMURA		HANGCHA/OKAMURA		HANGCHA/OKAMURA		HANGCHA/OKAMURA		HANGCHA/OKAMURA		HANGCHA/OKAMURA		HANGCHA/OKAMURA			
		Transmissions Type	Powershift		Powershift		Powershift		Powershift		Powershift		Powershift		Powershift		Powershift		Powershift		Powershift		Powershift		Powershift		Powershift		Powershift			
	Stage FWD/RVS	1/1		1/1		1/1		1/1		1/1		1/1		1/1		1/1		1/1		1/1		1/1		1/1		1/1		1/1				
Addition data	10.1	Operating pressure for attachments	bar	145	145	145	145	145	145	145	175	175	175	175	175	175	175	175	175	175	175	175	175	175	175	175	175	175				
	10.4	Fuel tank capacity	liter	50	35	50	50	35	50	50	35	50	50	60	50	70	50	70	50	70	50	70	50	70	50	70	50	70				

Note: *With suspension seat or cabin
*As a calculated value

Optional Engine / Transmission

Engine	Engine manufacturer / type	GCT GK21		YANMAR 4TNE92	GCT GK21 LPG	GCT GK21 LPG EU StageV	GCT GK21 LPG 16001 EKHO0	GCT GK21 DUAL 16001 ECHO0	KUBOTA V2607-CR-E5B	YANMAR 4TNE98	XINCHAI A4988T1	GCT GK25 LPG	GCT GK25	MITSUBISHI S4S-DPEU2	GCT GK25 LPG EU StageV	XINCHAI 3E22YG51P464	XINCHAI 3E22YG51	KUBOTA V2607-CR-TE5B	GCT GK25 LPG 16001 ELHO0	GCT GK25 DUAL 16001 EDHO0
	Manufacturer's type designation	W21		W32	W51	H1	H23	H24	W97	W33	W27	W52	W22	W55	H3	H7	H7	W98	H21	H22
	Drive	Gasoline	Gasoline/ DUAL FUEL/ LPG	Gasoline/ DUAL FUEL/ LPG	Diesel	LPG	LPG	DUAL LPG/GAS	Diesel	Diesel	Diesel	LPG	Gasoline DUAL FUEL/LPG	Diesel	LPG	Diesel	Diesel	Diesel	LPG	DUAL LPG/GAS
	Emission STD	--		EU StageIIIA	--	EU StageV	CARB Tier3/ EPA Tier2/ EU STAGE V		EU Stage V/ EPA Tier 4F	EU StageIIIA	EU StageIIIA	--	--	EU StageIIIA	EU StageV	EU StageV	EU StageV	EU StageV/EPA Tier4 F	CARB Tier3/ EPA Tier2/ EU Stage V	
	Engine power	kw/r/min	31.2/2250	32.8/2450	29/2250	38.4/2700	43/2700	LP:43/2700 /G:40/2700	37.4/2400	42.1/2300	36.8/2400	35/2400	37.4/2500	35.3/2250	43.4/2700	34/2400	44.8/2400	47.3/2400	47/2700	LP:47/2700 /G:44.5/2700
	Rated torque	N·m/r/min	143.7/1600	142/1600	140/1600	151/1600	161/2000	LP:161/2000/G:153/2000	171.5/1500	206/1700	186/1600-1800	170/1600	176.5/1600	177						

Technical data

Distinguishing mark	1.1	HANGCHA GROUP CO.,LTD.														
	1.2	CPYD15-XH23F/B1	CPYD18-XH23F/B1	CPYD20-XH21F/B1	CPYD25-XH21F/B1	CPYD30-XH21F/B1	CPYD35-XH21F/B1	CPYD35-XH21F/B1	CPYD35-XH21F/B1	CPYD35-XH21F/B1	CPYD35-XH21F/B1	CPYD35-XH21F/B1	CPYD35-XH21F/B1	CPYD35-XH21F/B1	CPYD35-XH21F/B1	
	1.3	Drive: electric (battery or mains), diesel, petrol, fuel gas	LPG	LPG	LPG	LPG	LPG	LPG	LPG	LPG/GAS	LPG/GAS	LPG/GAS	LPG/GAS	LPG/GAS	LPG/GAS	LPG/GAS
	1.5	Rated capacity/rated load	Q [kg]	1500	1750	2000	2500	3000	3500	1500	1750	2000	2500	3000	3500	
	1.6	Load centre distance	c[mm]	500	500	500	500	500	500	500	500	500	500	500	500	
	1.8	Load distance, centre of drive axle to fork	x[mm]	405	405	465	465	480	485	405	405	465	465	480	485	
		Rear overhang	mm	405	430	415	490	550	615	405	430	415	490	550	615	
	1.9	Wheelbase	y[mm]	1475	1475	1650	1650	1700	1700	1475	1475	1650	1650	1700	1700	
Weight	2.1	Service Weight	kg	2650	2765	3405	3765	4350	4705	2650	2765	3405	3765	4350	4705	
	2.2	Axle loading, laden front/rear	kg	3660/490	3995/520	4705/700	5475/790	6450/900	7255/950	3660/490	3995/520	4705/700	5475/790	6450/900	7255/950	
	2.3	Axle loading, unladen front/rear	kg	1240/1410	1225/1540	1610/1795	1560/2205	1750/2600	1720/2985	1240/1410	1225/1540	1610/1795	1560/2205	1750/2600	1720/2985	
Tyres, chassis	3.2	Tyre size, front		6.50-10-10PR	6.50-10-10PR	7.00-12-12PR	7.00-12-12PR	28x9-15-14PR	28x9-15-14PR	6.50-10-10PR	6.50-10-10PR	7.00-12-12PR	7.00-12-12PR	28x9-15-14PR	28x9-15-14PR	
	3.3	Tyre size, rear		5.00-8-10PR	5.00-8-10PR	6.00-9-10PR	6.00-9-10PR	6.50-10-10PR	6.50-10-10PR	5.00-8-10PR	5.00-8-10PR	6.00-9-10PR	6.00-9-10PR	6.50-10-10PR	6.50-10-10PR	
	3.6	Tread, front	b10 [mm]	900	900	965	965	1005	1005	900	900	965	965	1005	1005	
	3.7	Tread, rear	b11 [mm]	920	920	973	973	975	975	920	920	973	973	975	975	
Dimensions	4.1	Tilt of mast/fork carriage forward/backward	α/β(°)	6/12	6/12	6/12	6/12	6/12	6/12	6/12	6/12	6/12	6/12	6/12	6/12	
	4.2	Height, mast lowered	h1 [mm]	1995	1995	2035	2035	2050	2165	1995	1995	2035	2035	2050	2165	
	4.3	Free lift	h2 [mm]	155	155	140	140	145	145	155	155	140	140	145	145	
	4.4	Lift	h3 [mm]	3000	3000	3000	3000	3000	3000	3000	3000	3000	3000	3000	3000	
	4.5	Height, mast extended	h4 [mm]	3955	3955	4045	4045	4145	4145	3955	3955	4045	4045	4145	4145	
	4.7	Height of overhead guard (cabin)	h6 [mm]	2125(2205*)	2125(2205*)	2135(2215*)	2135(2215*)	2150(2230*)	2150(2230*)	2125(2205*)	2125(2205*)	2135(2215*)	2135(2215*)	2150(2230*)	2150(2230*)	
	4.20	Length to face of forks	l2 [mm]	2285	2310	2530	2605	2730	2800	2285	2310	2530	2605	2730	2800	
	4.21	Overall width	b1 [mm]	1080	1080	1155	1155	1225	1225	1080	1080	1155	1155	1225	1225	
	4.22	Fork dimensions	s/e/l [mm]	920x100x35	920x100x35	1070x122x40	1070x122x40	1070x122x45	1070x122x50	920x100x35	920x100x35	1070x122x40	1070x122x40	1070x122x45	1070x122x50	
	4.24	Fork-carriage width	b3 [mm]	1000	1000	1038	1038	1100	1100	1000	1000	1038	1038	1100	1100	
	4.25	Distance between fork-arms	mm	200-1000	200-1000	244-1038	244-1038	244-1100	244-1100	200-1000	200-1000	244-1038	244-1038	244-1100	244-1100	
	4.31	Ground clearance, laden, below mast	m1 [mm]	115	115	115	115	130	130	115	115	115	115	130	130	
	4.32	Ground clearance, centre of wheelbase	m2 [mm]	140	140	150	150	165	165	140	140	150	150	165	165	
	4.35	Turning radius	Wa [mm]	1990	2015	2180	2245	2340	2415	1990	2015	2180	2245	2340	2415	
			Min. right angle stacking aisle width (Add load length and clearance)	mm	2395	2420	2645	2710	2835	2900	2395	2420	2645	2710	2835	2900
Performance data	5.1	Travel speed, laden/unladen	km/h	17/18	17/18	18/19	18/19	17/18	17/18	17/18	17/18	18/19	18/19	17/18	17/18	
	5.2	Lift speed, laden/unladen	m/s	0.53/0.55	0.53/0.55	0.56/0.58	0.56/0.58	0.51/0.54	0.46/0.49	0.53/0.55	0.53/0.55	0.56/0.58	0.56/0.58	0.51/0.54	0.46/0.49	
	5.3	Lowering speed, laden/unladen	m/s	0.45/0.50	0.45/0.50	0.45/0.50	0.45/0.50	0.45/0.50	0.45/0.50	0.45/0.50	0.45/0.50	0.45/0.50	0.45/0.50	0.45/0.50	0.45/0.50	
	5.5	Drawbar pull, laden/unladen	N	15800/10000	15800/10000	18700/12500	18700/12500	19800/14000	19800/14000	15800/10000	15800/10000	18700/12500	18700/12500	19800/14000	19800/14000	
	5.7	Gradeability, laden/unladen*	%	29/25	26/25	26/25	23/25	21/22	20/22	29/25	26/25	26/25	21/22	21/22	20/22	
Combustion-engine	7.1	Engine manufacturer/type		GCT GK21 LPG	GCT GK21 LPG	GCT GK25 LPG	GCT GK25 LPG	GCT GK25 LPG	GCT GK25 LPG	GCT GK21 DUAL	GCT GK21 DUAL	GCT GK25 DUAL	GCT GK25 DUAL	GCT GK25 DUAL	GCT GK25 DUAL	
		Emission STD		CARB Tier3/ EPA Tier2/ EU StageV	CARB Tier3/ EPA Tier2/ EU StageV	CARB Tier3/ EPA Tier2/ EU StageV	CARB Tier3/ EPA Tier2/ EU StageV	CARB Tier3/ EPA Tier2/ EU StageV	CARB Tier3/ EPA Tier2/ EU StageV	CARB Tier3/ EPA Tier2/ EU StageV	CARB Tier3/ EPA Tier2/ EU StageV	CARB Tier3/ EPA Tier2/ EU StageV	CARB Tier3/ EPA Tier2/ EU StageV	CARB Tier3/ EPA Tier2/ EU StageV	CARB Tier3/ EPA Tier2/ EU StageV	
	7.2	Engine power according to DIN ISO 1585	kw	43	43	47	47	47	47	43	43	47	47	47	47	
	7.3	Rated speed	min	2700	2700	2700	2700	2700	2700	2700	2700	2700	2700	2700	2700	
	7.4	Number of cylinders/displacement	(-)/[cm³]	4/2065	4/2065	4/2488	4/2488	4/2488	4/2488	4/2065	4/2065	4/2488	4/2488	4/2488	4/2488	
	7.10	Battery voltage/nominal capacity	V/Ah	12/60	12/60	12/60	12/60	12/60	12/60	12/60	12/60	12/60	12/60	12/60	12/60	
		Rated torque	N·m/r/min	161/2000	161/2000	190/2000	190/2000	190/2000	190/2000	161/2000	161/2000	190/2000	190/2000	190/2000	190/2000	
		Bore • stroke	mm	89x83	89x93	89x100	89x100	89x100	89x100	89x83	89x83	89x100	89x100	89x100	89x100	
		Transmissions Manufacturer		HANGCHA/OKAMURA	HANGCHA/OKAMURA	HANGCHA/OKAMURA	HANGCHA/OKAMURA	HANGCHA/OKAMURA	China/OKAMURA	China/OKAMURA	China/OKAMURA	China/OKAMURA	China/OKAMURA	China/OKAMURA	China/OKAMURA	
		Transmissions Type		Powershift	Powershift	Powershift	Powershift	Powershift	Powershift	Powershift	Powershift	Powershift	Powershift	Powershift	Powershift	
	Stage FWD/RVS		1/1	1/1	1/1	1/1	1/1	1/1	1/1	1/1	1/1	1/1	1/1	1/1		
Addition data	10.1	Operating pressure for attachments	bar	145	145	175	175	175	175	145	145	175	175	175		
	10.4	Fuel tank capacity	liter	35	35	50	50	50	50	35	35	50	50	50		

Note: *With suspension seat or cabin
* As a calculated value

Optional Engine / Transmission

Engine	Engine manufacturer/type	GCT GK21			YANMAR 4TNE92	GCT GK21 LPG	GCT GK21 LPG EU StageV	GCT GK21 LPG 16001 EKHO0	GCT GK21 DUAL 16001 ECHO0	KUBOTA V2607-CR-E58	YANMAR 4TNE98	XINCHAI A4988T1	GCT GK25 LPG	GCT GK25	MITSUBISHI S4S-DPEU2	GCT GK25 LPG EU StageV	XINCHAI 3E22YG51P464	XINCHAI 3E22YG51	KUBOTA V2607-CR-TE58	GCT GK25 LPG 16001 ELHO0	GCT GK25 DUAL 16001 EKH00	
	Manufacturer's type designation	W21			W32	W51	H1	H23	H24	W97	W33	W27	W52	W22	W55	H3	H7	H7	W98	H21	H22	
	Drive	Gasoline	Gasoline/ DUAL FUEL/ LPG	Gasoline/ DUAL FUEL/ LPG	Diesel	LPG	LPG	LPG	DUAL LPG/GAS	Diesel	Diesel	LPG	Gasoline DUAL FUEL/LPG	Diesel	LPG	Diesel	Diesel	Diesel	Diesel	LPG	DUAL LPG/GAS	
	Emission STD	--			EU StageIIIA	--	EU StageV	CARB Tier3/ EPA Tier2/ EU STAGE V		EU Stage V/ EPA Tier 4F	EU StageIIIA	EU StageIIIA	--	--	EU StageIIIA	EU StageV	EU StageV	EU StageV	EU StageV/ EPA Tier 4F	CARB Tier3/ EPA Tier2/ EU Stage V		
	Engine power	kw/r/min	31.2/2250			32.8/2450	29/2250	38.4/2700	43/2700	LP:43/2700 /G:40/2700	37.4/2400	42.1/2300	36.8/2400	35/2400	37.4/2500	35.3/2250	43.4/2700	34/2400	44.8/2400	47.3/2400	47/2700	LP:47/2700 /G:44.5/2700
	Rated torque	N·m/r/min	143.7/1600			142/1600	140/1600	151/1600	161/2000	LP:161/2000/G:153/2000	171.5/1500	206/1700	186/1600-1800	170/1600	176.5/1600	177/1700	188/1600	150/1600-1800	210/1600-1800	221.7/1500	190/2000	LP:190/2000/G:175/2000
	Number of cylinders/displacement	ml	4/2065			4/2659	4/2065	4/2065	4/2065	4/2615	4/3319	4/3168	4/2488	4/2488	4/3331	4/2488	3/2227	3/2227	4/2615	4/2488	4/2488	
Transmission	Powershift	F(CHINA)	F	✓	✓	✓	✓	✓	✓	✓	✓	✓	✓	✓	✓	✓	✓	✓	✓	✓	✓	
		OKAMURA(JAPAN)	B	✓	✓	X	✓	X	✓	X	✓	✓	X	✓	✓	X	✓	✓	✓	X	✓	✓
Rated capacity/rated load		Q [kg]	1000	1500-1750	2000	1000-1750	2000-2500	1500-1750	2000-2500	1500-1750	1500-1750	1500-1750	1500-1750	1500-1750	1500-1750	1500-1750	1500-1800	2000-3500	2000-3500	2000-3500	2000-3500	2000-3500

1.0-1.75t XF series mast: (pneumatic)

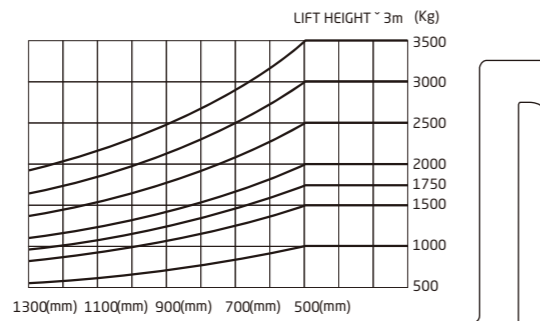
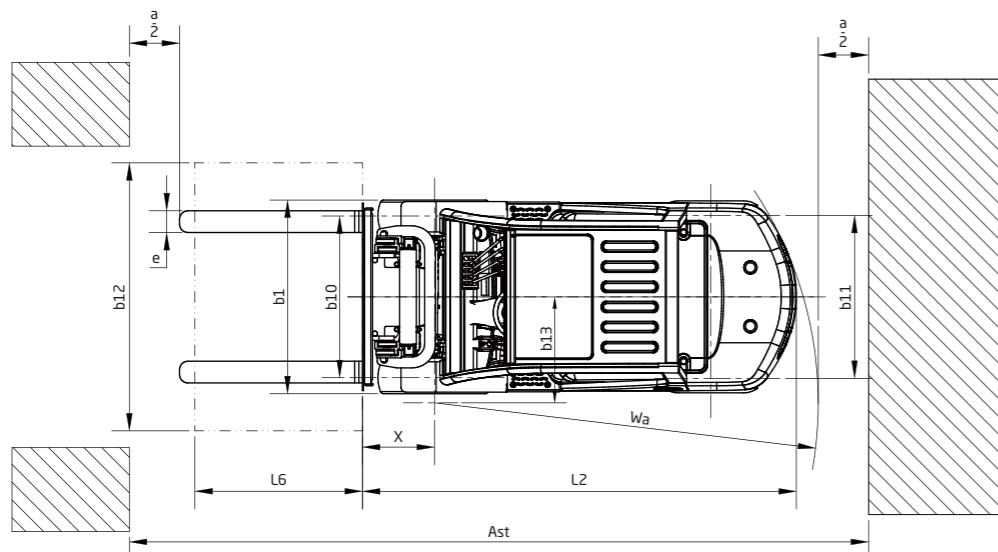
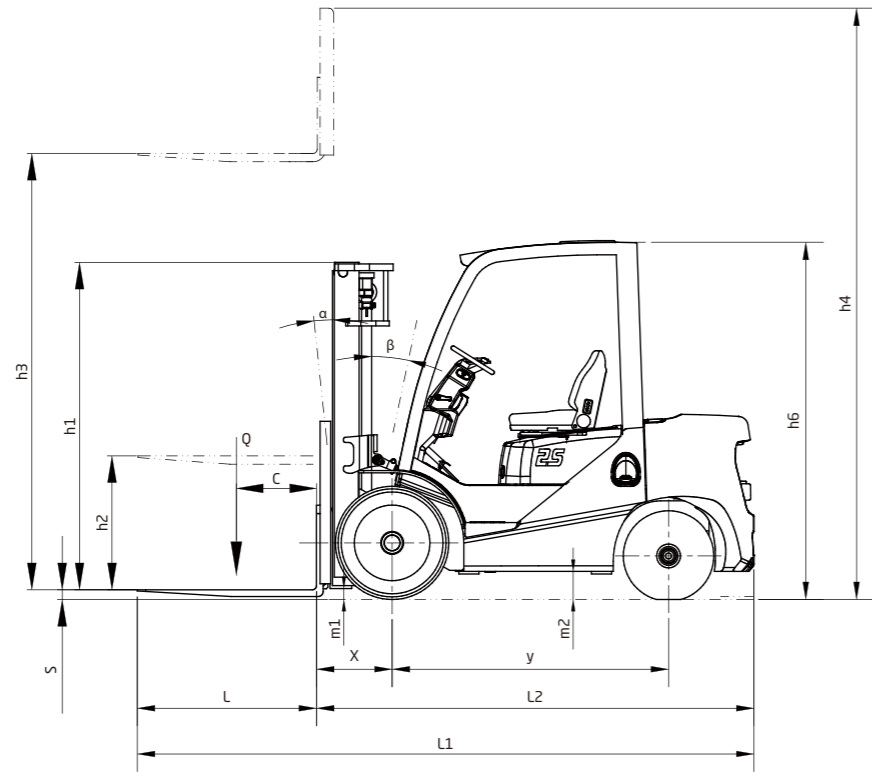

Type	Model	Max. fork height	Overall height				Free lift			Front overhang		Tilt range		Capacity				
			Lowered	Extended		Without backrest	With backrest	1 / 1.5t	1.75t	1 / 1.5	1.75t	FWD	BWD	Load capacity at 500mm				
				Without backrest	With backrest									Single tire		Dual tire		
														1t	1.5t	1.75t	1t	1.5t
Wide view mast	X15/18M200	2000	1495	2565	2955	155	160	155	405	410	6	6	1000	1500	1750	1000	1500	1750
	X15/18M250	2500	1745	3065	3455	155	160	155	405	410	6	12	1000	1500	1750	1000	1500	1750
	X15/18M270	2700	1845	3265	3655	155	160	155	405	410	6	12	1000	1500	1750	1000	1500	1750
	X15/18M300	3000	1995	3565	3955	155	160	155	405	410	6	12	1000	1500	1750	1000	1500	1750
	X15/18M330	3300	2145	3865	4255	155	160	155	405	410	6	12	1000	1500	1750	1000	1500	1750
	X15/18M350	3500	2245	4065	4455	155	160	155	405	410	6	12	1000	1500	1750	1000	1500	1750
	X15/18M370	3700	2395	4265	4655	155	160	155	405	410	6	12	1000	1500	1750	1000	1500	1750
	X15/18M400	4000	2595	4565	4955	155	160	155	405	410	6	12	1000	1500	1650	1000	1500	1700
	X15/18M430	4300	2745	4865	5255	155	160	155	405	410	6	6	950	1450	1600	1000	1450	1650
	X15/18M450	4500	2845	5065	5455	155	160	155	405	410	6	6	900	1400	1550	950	1400	1600
	X15/18M470	4700	2945	5265	5655	155	160	155	405	410	6	6	850	1350	1500	900	1350	1550
	X15/18M480	4800	2995	5365	5755	155	160	155	405	410	6	6	850	1350	1500	900	1350	1550
	X15/18M500	5000	3095	5565	5955	155	160	155	405	410	6	6	800	1300	1450	850	1300	1500
	X15/18M550	5500	3345	6065	6455	155	160	155	405	410	6	6	750	1250	1400	800	1250	1450
	X15/18M600	6000	3595	6565	6955	155	160	155	405	410	6	6	700	1200	1350	750	1200	1400
Wide view full free duplex mast	X15/18U200	2000	1560	2585	2945	975	975	815	405	410	6	6	1000	1500	1750	1000	1500	1750
	X15/18U250	2500	1810	3085	3445	1225	1225	865	405	410	6	12	1000	1500	1750	1000	1500	1750
	X15/18U270	2700	1910	3285	3645	1325	1325	965	405	410	6	12	1000	1500	1750	1000	1500	1750
	X15/18U300	3000	2010	3585	3945	1425	1425	1065	405	410	6	12	1000	1500	1750	1000	1500	1750
	X15/18U330	3300	2160	3885	4245	1575	1575	1215	405	410	6	12	1000	1500	1750	1000	1500	1750
	X15/18U350	3500	2260	4085	4445	1675	1675	1315	405	410	6	12	1000	1500	1750	1000	1500	1750
	X15/18U370	3700	2360	4285	4645	1775	1775	1415	405	410	6	12	1000	1500	1750	1000	1500	1750
	X15/18U400	4000	2560	4585	4945	1975	1975	1615	405	410	6	12	1000	1500	1650	1000	1500	1700
	X15/18N400	4000	1970	4680	4955	1300	1300	1025	420	425	6	6	900	1400	1550	950	1400	1600
	X15/18N430	4300	2070	4980	5255	1400	1400	1125	420	425	6	6	850	1350	1500	900	1350	1550
	X15/18N450	4500	2120	5130	5455	1500	1500	1175	420	425	6	6	800	1300	1450	850	1300	1500
	X15/18N470	4700	2170	5295	5655	1585	1585	1225	420	425	6	6	750	1250	1400	800	1250	1450
	X15/18N480	4800	2220	5430	5755	1600	1600	1275	420	425	6	6	750	1250	1400	800	1250	1450
	X15/18N500	5000	2270	5595	5955	1685	1685	1325	420	425	6	6	700	1200	1350	750	1200	1400
	X15/18N550	5500	2470	6095	6455	1885	1885	1525	420	425	3	6	650	950	1050	750	1150	1300
X15/18N600	6000	2720	6730	7005	2050	2050	1775	420	425	3	6	600	700	750	700	1050	1150	
X15/18N650	6500	2870	7160	7455	2200	2200	1925	420	425	3	6	600	700	750	700	1050	1150	
X15/18N700	7000	3020	7630	7955	2385	2385	2025	420	425	3	6	600	700	750	700	1050	1150	

With sideshifter minus 150kg, with integral sideshifter minus 100kg.

2.0-2.5t XF series mast: (pneumatic)

Type	Model	Max. fork height	Overall height				Free lift		Front overhang	Tilt range		Capacity			
			Lowered	Extended		Without backrest	With backrest	FWD		BWD	Load capacity at 500mm				
				Without backrest	With backrest						Single tire		Dual tire		
											2.0t	2.5t	2.0t	2.5t	
Wide view mast	X25M200	2000	1535	2660	3045	140	140	465	6	6	2000	2500	2000	2500	
	X25M250	2500	1795	3160	3545	140	140	465	6	12	2000	2500	2000	2500	
	X25M270	2700	1895	3360	3745	140	140	465	6	12	2000	2500	2000	2500	
	X25M300	3000	2035	3660	4045	140	140	465	6	12	2000	2500	2000	2500	
	X25M330	3300	2185	3960	4345	140	140	465	6	12	2000	2500	2000	2500	
	X25M350	3500	2285	4160	4545	140	140	465	6	12	2000	2500	2000	2500	
	X25M370	3700	2435	4360	4745	140	140	465	6	12	2000	2500	2000	2500	
	X25M400	4000	2635	4660	5045	140	140	465	6	12	2000	2500	2000	2500	
	X25M430	4300	2785	4960	5365	140	140	465	6	6	1950	2400	2000	2450	
	X25M450	4500	2885	5160	5545	140	140	465	6	6	1950	2300	1950	2350	
	X25M470	4700	2985	5360	5745	140	140	465	6	6	1850	2250	1900	2300	
	X25M480	4800	3035	5460	5845	140	140	465	6	6	1850	2150	1900	2250	
	X25M500	5000	3135	5660	6045	140	140	465	6	6	1800	1850	1850	2100	
	X25M550	5500	3385	6160	6545	140	140	465	3	6	1600	1600	1600	1900	
	X25M600	6000	3635	6660	7045	140	140	465	3	6	1400	1400	1400	1750	
Wide view full free duplex mast	X25U200	2000	1560	2680	3045	880	510	465	6	6	2000	2500	2000	2500	
	X25U250	2500	1810	3180	3545	1130	760	465	6	12	2000	2500	2000	2500	
	X25U270	2700	1910	3380	3745	1230	860	465	6	12	2000	2500	2000	2500	
	X25U300	3000	2010	3680	4045	1330	960	465	6	12	2000	2500	2000	2500	
	X25U330	3300	2160	3980	4345	1480	1110	465	6	12	2000	2500	2000	2500	
	X25U350	3500	2260	4180	4545	1580	1210	465	6	12	2000	2500	2000	2500	
	X25U370	3700	2360	4380	4745	1680	1310	465	6	12	2000	2500	2000	2500	
	X25U400	4000	2560	4680	5045	1880	1510	465	6	12	2000	2450	2000	2500	
	X25N400	4000	2000	4700	5045	1300	955	480	6	6	1950	2450	1950	2500	
	X25N430	4300	2100	5000	5345	1400	1055	480	6	6	1900	2400	1950	2450	
	X25N450	4500	2150	5230	5595	1470	1105	480	6	6	1850	2300	1850	2300	
	X25N470	4700	2200	5380	5745	1520	1155	480	6	6	1800	2250	1800	2300	
	X25N480	4800	2250	5480	5845	1570	1205	480	6	6	1750	2100	1800	2200	
	X25N500	5000	2300	5680	6045	1620	1255	480	6	6	1700	1900	1800	2100	
	X25N550	5500	2500	6180	6545	1820	1455	480	3	6	1450	1600	1600	1900	
X25N600	6000	2750	6750	7095	2050	1705	480	3	6	1000	1050	1400	1750		
X25N650	6500	2900	7200	7545	2200	1855	480	3	6	1000	1050	1400	1750		
X25N700	7000	3050	7680	8045	2370	2005	480	3	6	1000	1050	1400	1750		

With sideshifter minus 150kg, with integral sideshifter minus 100kg.

3.0-3.5t XF series mast: (pneumatic)

Type	Model	Max. fork height	Overall height				Free lift				Front overhang		Tilt range		Capacity					
			Lowered (mm)	Extended		Without backrest (mm)	With backrest (mm)	Without backrest (mm)	With backrest (mm)	FWD	BWD	Load capacity at 500mm								
				Without backrest	With backrest							Single tire (kg)		Dual tire (kg)						
												3.0t	3.5t	3.0t	3.5t					
Wide view mast	X30/35M200	2000	1550	1665	2735	2805	3145	3145	145	145	145	145	480	485	6	6	3000	3500	3000	3500
	X30/35M250	2500	1800	1915	3235	3305	3645	3645	145	145	145	145	480	485	6	12	3000	3500	3000	3500
	X30/35M270	2700	1900	2015	3435	3505	3845	3845	145	145	145	145	480	485	6	12	3000	3500	3000	3500
	X30/35M300	3000	2050	2165	3735	3805	4145	4145	145	145	145	145	480	485	6	12	3000	3500	3000	3500
	X30/35M330	3300	2200	2315	4035	4105	4445	4445	145	145	145	145	480	485	6	12	3000	3500	3000	3500
	X30/35M350	3500	2300	2415	4235	4305	4645	4645	145	145	145	145	480	485	6	12	3000	3500	3000	3500
	X30/35M370	3700</																		