

## A Series Mini Range Pallet Stacker With Initial Lift Specification

		HANGCHA GROUP CO.,LTD.	
Distinguishing mark	1.1	Manufacturer	
	1.2	Manufacturer's type designation	CDD10-AMC2-L CDD12-AMC2-L
Weight	1.4	Operator type: hand, pedestrian, standing, seated, order-picker	Pedestrian Pedestrian
	1.5	Rated capacity/rated load	Q (kg) 1000 1200
	1.6	Load centre distance	c (mm) 600 600
	1.9	Wheelbase	y (mm) 1281 1281
	2.1	Service Weight(Including battery)	kg 760 760
Tyres, chassis		Battery Weight	kg 66 66
	3.1	Tyres: solid rubber, superelastic, pneumatic, polyurethane	PU PU
	3.2	Tyre size, front	Φ250x80 Φ250x80
	3.3	Tyre size, rear	Φ75x64 Φ75x64
	3.4	Additional wheel (dimensions)	Φ125x50 Φ125x50
	3.5	Wheels, number front / rear (x = driven wheels)	1x+1/4 1x+1/4
	3.6	Tread, front	b10 (mm) 520 520
	3.7	Tread, rear	b11 (mm) 385 385
	4.4	Lift	h3 (mm) 3000 3000
	4.6	initial lift	h5 (mm) 120 120
Dimensions	4.9	Height drawbar in driving position min./max.	h14 (mm) 720/1220 720/1220
	4.15	Fork height,lowered	h13 (mm) 86 86
	4.19	Overall length(folded pedal)	l1 (mm) 1807 1807
	4.21	Overall width	b1 (mm) 800 800
	4.22	Fork dimensions	s/e/l (mm) 60/185/1150 60/185/1150
	4.25	Distance between fork-arms	b5 (mm) 570 570
	4.32	Ground clearance, centre of wheelbase	m2 (mm) 21 21
	4.34.1	Aisle width for pallets 1000 x 1200 crossways	Ast (mm) 2010 <sup>1)</sup> 2010 <sup>2)</sup>
	4.34.2	Aisle width for pallets 800 x 1200 lengthways	Ast (mm) 2060 <sup>1)</sup> 2060 <sup>2)</sup>
	4.35	Turning radius	Wa (mm) 1415 <sup>1)</sup> 1415 <sup>2)</sup>
Performance data	5.1	Travel speed,laden/unladen	km/h 6/6 6/6
	5.2	Lift speed,laden/unladen	m/s 0.115/0.150 0.110/0.150
	5.3	Lowering speed,laden/unladen	m/s 0.140/0.135 0.140/0.135
	5.8	Max Gradeability,laden/unladen	% 8/16 8/16
Electric engine	6.1	Drive motor rating S2 60 min	kW 1.1 1.1
	6.2	Lift motor rating at S3 15%	kW 2.2 2.2
	6.4	Battery voltage,rated capacity	V/Ah 2x12/106 2x12/106
	8.1	Type of drive control	AC AC
	9.1	Manufacturer	Curtis Curtis

Note: 1) VDI 2198: +260mm 2) VDI 2198: +165mm 3) Load section lowered: +60mm

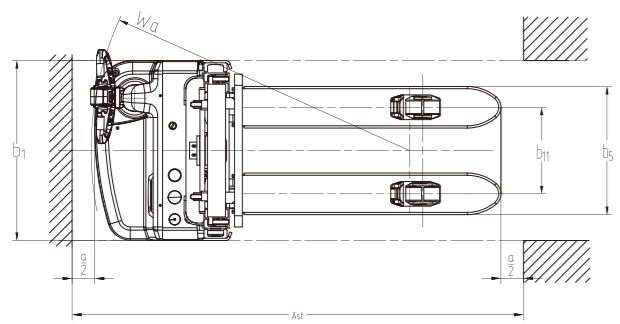
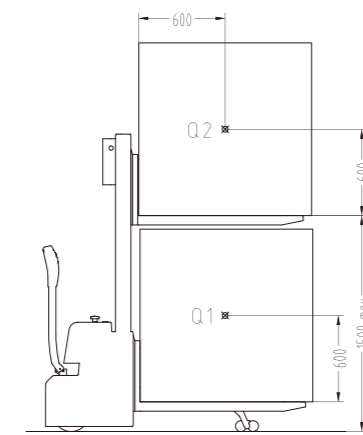
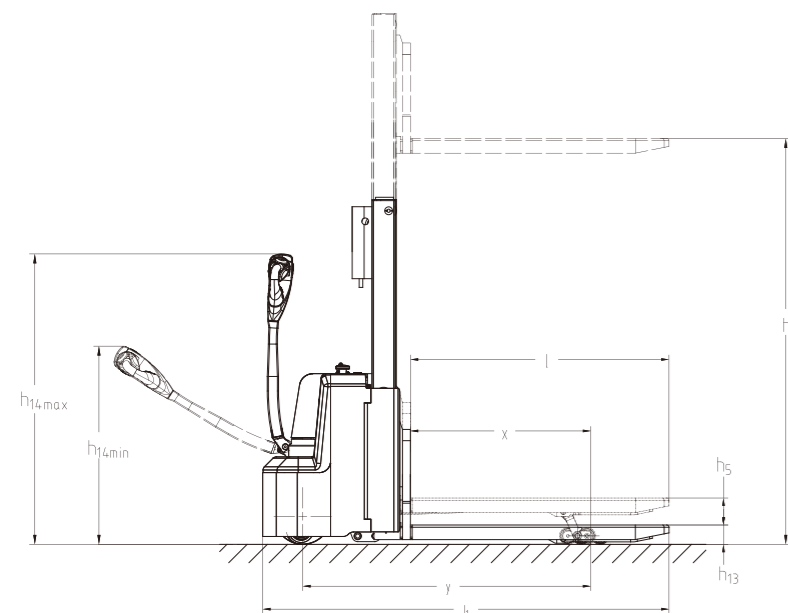

Q1(kg)		Q2(kg)		Q1+Q2(kg) max
max	min	max	min	
1200	0	0	0	1200
1100	100	100	0	1200
1000	200	200	0	
900	300	300	0	
800	400	400	0	
700	500	500	0	
600	600	600	0	

## A Series Mini Range Pallet Stacker With Initial Lift Mast Specification:

Mast Type	Max Lifting Height h3	Max. fork height (h3+h13)	Lowered Height h1	Extended Height h4	Free lift	Load Capacity at 600mm	
						1.0t	1.2t
Single cylinder duplex mast	mm	mm	mm	mm	mm	Kg	Kg
	2000	2086	1576	2576	0	1000	1200
	2500	2586	1826	3076	0	1000	1000
	2700	2786	1926	3276	0	900	900
	3000	3086	2076	3576	0	800	800
	3300	3386	2226	3876	0	700	700
	3500	3586	2411	4161	0	550	550
3600	3686	2461	4261	0	550	550	



## A Series Mini Range Pallet Stacker With Initial Lift

with capacities of 1,000 to 1,200kg



ZHEJIANG HANGCHA IMP. & EXP. CO., LTD.

Factory site: 666 Xiangfu Road, Hangzhou, Zhejiang, China (311305)

Tel: +86-571-88926735 88926755  
Fax: +86-571-88926789 88132890

sales@hcforklift.com  
www.hcforklift.com



Follow us on Facebook



Follow us on YouTube



Follow us on WeChat



Download "Hangcha Forklift" App



ISO14001:2015



ISO9001:2015



HANGCHA trucks conform to the European Safety Requirements.

HANGCHA GROUP CO.,LTD. reserves the right to make any changes without notice concerning colors, equipment, or specifications detailed in this brochure, or to discontinue individual models. The colors of trucks, delivered may differ slightly from those in brochures.

2022 VERSION 1/COPYRIGHT 2022/05

The World of Hangcha  
SINCE 1956



# A Series Mini Range Pallet Stacker With Initial Lift

The A series mini range pallet stacker with initial lift is a new product developed by Hangcha for warehousing and logistics applications. It has a compact body, and can be operated easily and is suitable for operation in narrow aisles. It can carry out double pallet handling through leg lifting and is ideal for loading in warehouses, supermarkets, and workshops.

## Easy/ Efficiency/ Economy

### Appearance

- / The A series mini range pallet stacker with initial lift adopts a professional industrial design of appearance.
- / Applied steel stamping and injection molding processes, which is robust, durable, and also environmental compliance.



### Performance

- / The stacker can meet most needs of customers with its high power.
- / Powered by traction motor not only has good acceleration and perfect performance, but also low heat.
- / Latest CURTIS control system, precise and smooth.
- / Regenerative braking for battery recovery during travel speed reduction, anti-slope on gradient.

### Maintenance

- / Built-in charger and maintenance free gel battery, you don't need to worry about them.
- / Maintenance-free AC motor can reduce the cost significantly.
- / Integrated battery indicator, hour meter and self-diagnostic instrument.
- / Full opened rear hood, easy accessibility of all components, is easy for service.
- / All shafts installed lubricated shaft sleeve and oil cup, provide convenient maintenance and long service life.

### Reliability

- / With a high-strength steel frame structure, the vehicle frame has a large residual load capacity and a long service life.
- / 4-pivot design provide longer working life.
- / Imported waterproof connectors, all wires and cables are protected, greatly improve the reliability of the electric system.
- / Top quality hydraulic power unit applied to provide low noise, low vibration, smooth lifting and landing reliable operation.
- / The hydraulic unit and the vehicle frame are flexibly connected so that the vibration transmitted from the road surface to the hydraulic unit can be absorbed and the reliability of the hydraulic unit is improved.
- / Punch formed forks to provide more strength and tip guide to provide higher efficient operation.

### Safety

- / Three braking system of regenerative braking, reverse current braking, parking brake, insures the safe operation.
- / Anti-slope on gradient can keep the safety.
- / The emergency button on the tiller head can effectively avoid the harm to the driver.
- / The standard equipped electronic lifting limitation protect the pump motor from damaging dramatically and more energy saving.

### Comfort

- / Optimized designing structure to offer a good visibility and easy entrance of the pallet.
- / The compact body and semicircular design provide an ideal operation in limited space, and the ability of walking upright greatly increases the convenience in the container.

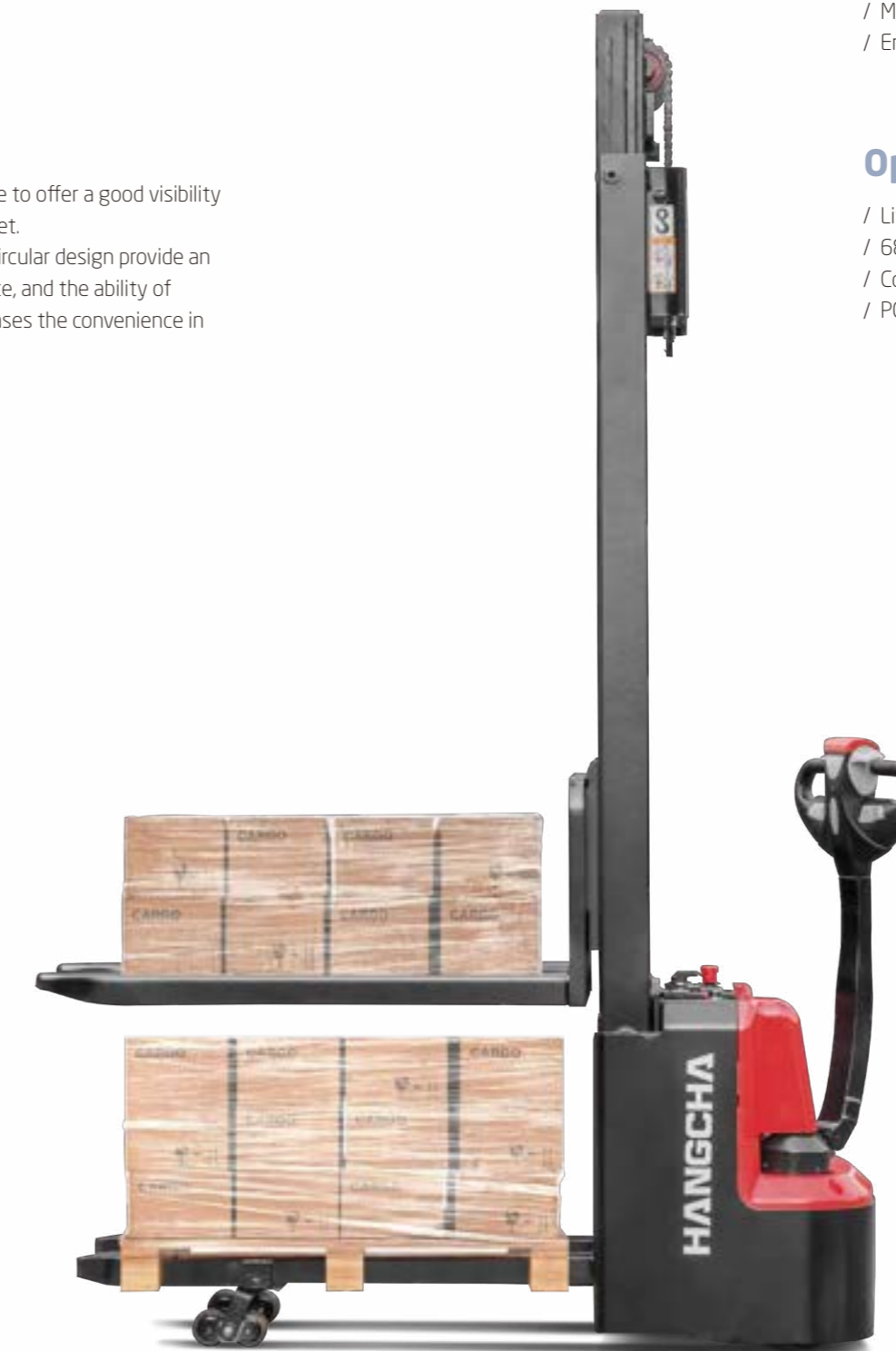

### Standard specification

- / AC traction motor
- / CURTIS controller
- / Hydraulic power unit
- / Multi-function battery indicator
- / Polyurethane tyre
- / 1150mm fork length
- / 560mm outside fork width
- / Horn
- / Maintenance-free battery
- / Built-in charger
- / Multi-function tiller
- / Emergency switch

### Options

- / Lift height: 2.0~3.6m
- / 680mm outside fork width
- / Cold storage
- / PC board



The pallet stacker with initial lift provides, higher efficiency and better passing ability



Optimized designing structure to offer a good visibility and easy entrance to the pallet



Built-in charger and maintenance free gel battery adopted to provide convenient usage

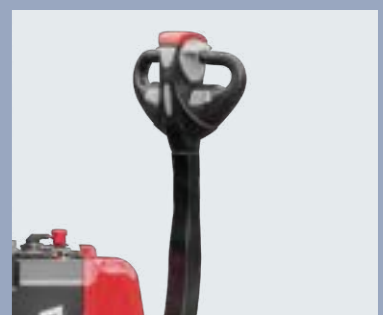

Simple and beautiful tiller designed to improve the operator's driving comfort